

# BPH SERIES

## Spin Torsional Test System

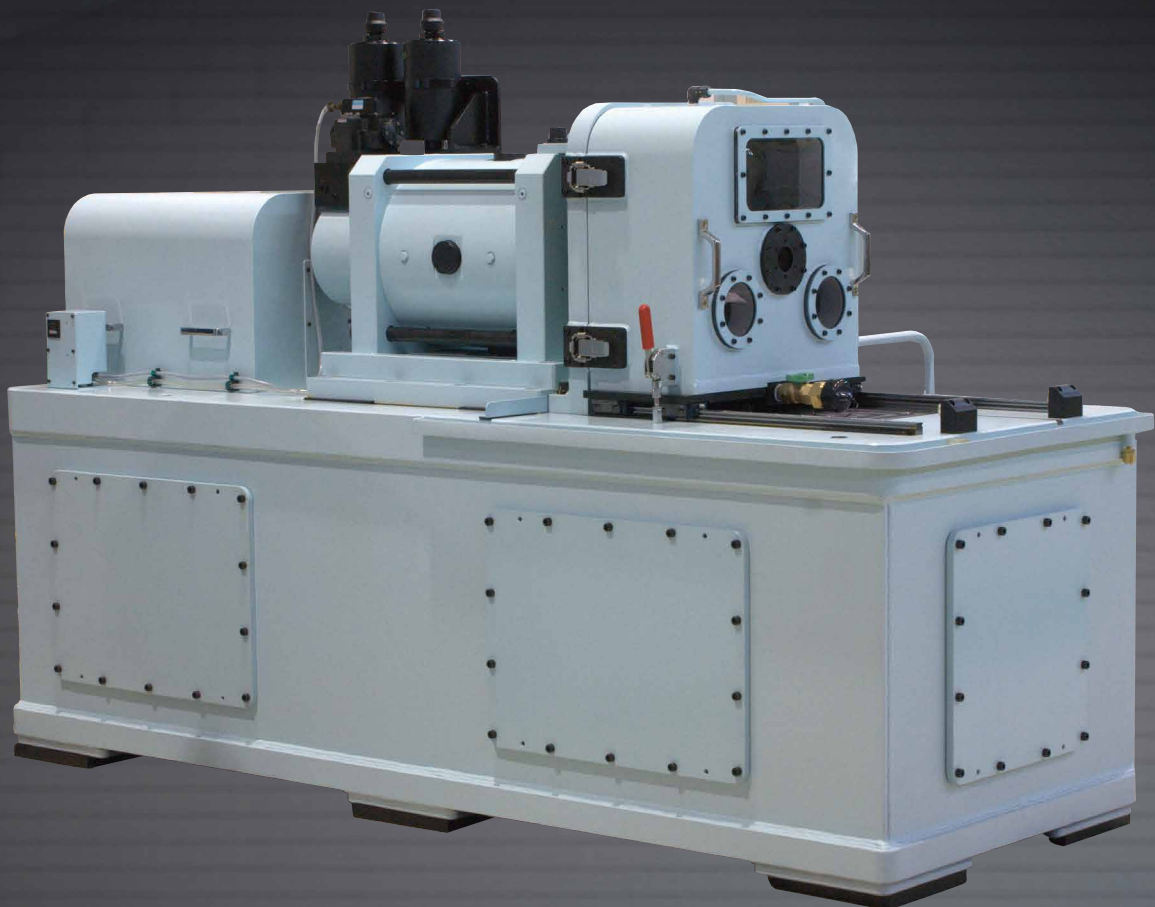

# Spin Torsional Test System

## Required performance for clutch damper

Clutch damper serves an important role to absorb/attenuate abnormal idling noise (rattling) on rotating drive system, strange running noise (rattling in acceleration/deceleration or booming noise), and also oscillation such as chip-in chip-out shock.

To satisfy this role, characteristic of damper and hysteresis should be researched and developed.

High durability on clutch is demanded under severe conditions, for centrifugal force load occurred from rotating and torque load during oscillation absorption as well as characteristic change occurred from friction wearing.

Spin Torsional Test System produced by Saginomiya is a necessary test tool to develop clutch damper under severe conditions.

## Required test for clutch damper

### ■ Test purpose

Spin Torsional Test System can apply dynamic oscillation load of angle/torque to damper when clutch is rotating in durability test.

As centrifugal force is applied that does not occur without rotation, its load condition is as similar as possible to that of the actual vehicle running.

It also measures characteristic of static spring and hysteresis.

### ■ Test items

- Standing wave durability by rotation + dynamic actuation
- Static spring characteristic by rotation + static actuation



MT clutch damper

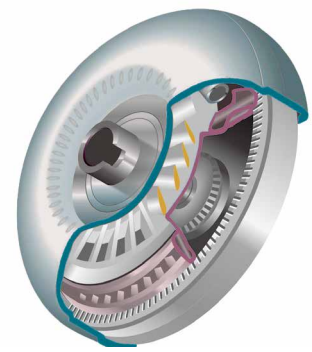

AT torque converter damper

## Overview of operation

Output shaft on Spin Torsional Test System is composed of outer shaft and inner shaft.

Connected by AC vector motor and belt to rotate by 200 ~ 8000rpm, outer shaft reproduces mean rotating velocity on engine. Embedded in the rotating outer shaft to perform relative oscillation to the outer shaft, inner shaft reproduces angle load and torque load to clutch damper occurred from ON/OFF acceleration or driving torsional oscillation. (standing wave actuation)

Spin Torsional Test System manufactured originally by Saginomiya can apply rotating load and torque/angle load simultaneously to clutch damper.

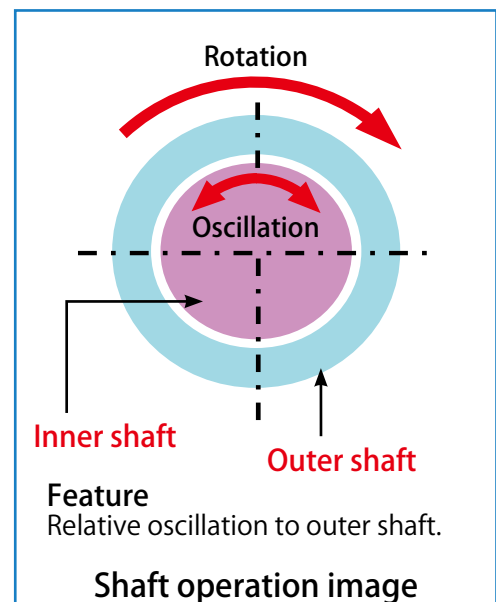
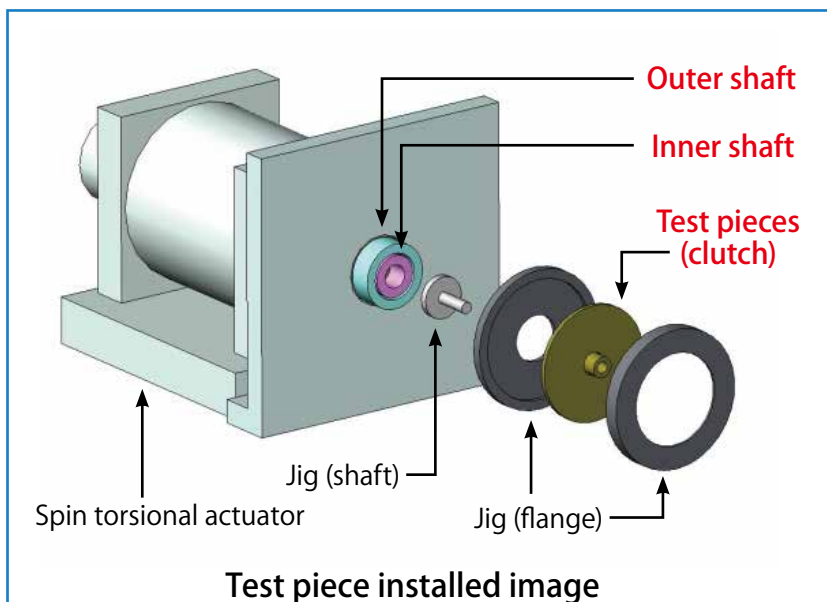

# Spin Torsional Test System

## Features

- Durability test and static spring characteristic test under as similar conditions as possible to when it is installed in the actual vehicle**
  - Dynamic torque load or angle load test on damper when clutch is rotating with centrifugal force.
  - ATF with supply lubricating oil circulation. ATF its temperature can set up from +60 to +120°C and lubrication conditions can be simulated as same conditions with actual vehicle.
- Large torque + wide angle test from low to the highest rotation**
  - Mean rotating velocity on AC vector motor and oscillation on hydraulic actuator. Large torque + wide angle test only with electric and hydraulic hybrid.
- Stable control even with clutch of strong non-linearity and dead-zone**
  - Stable control on peak torque even when damper stopper is hit.
  - Stable control even when dead-zone is passed through.
- Schedule test by combining durability test and static characteristic test**
  - "Spin Torsional Test Software" is attached, combining rotation and oscillation.
- Monitoring of torsional angle and torque and amplitude control**
  - Angle sensor and torque sensor are built-in inside of spin torsional actuator.

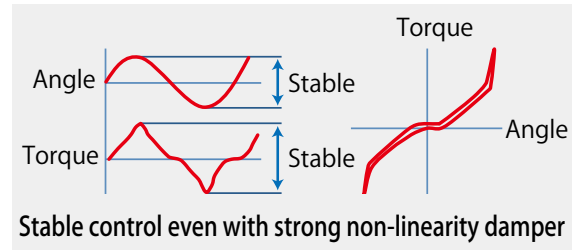

## Software

### Schedule operation

Schedule test up to 30 stages optionally combining conditions of durability test and static spring characteristic. Repeated 1000 tests at maximum through schedules.

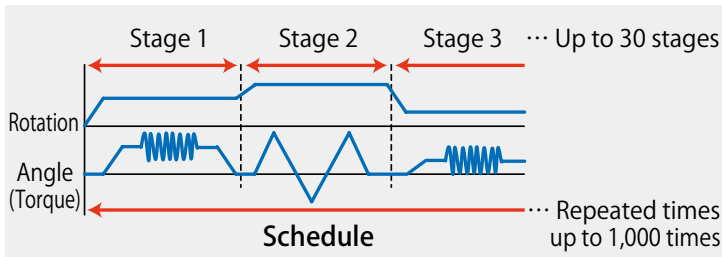

note: Optionally combined test with durability test mode and static spring test mode.

### Set items and measure

	Set	Measure	Analog output	Digital data
Rotational velocity	✓	✓	✓	✓
Actuating frequency	✓	✓	✓	✓
Actuating angle	✓	✓	✓	✓
Actuating torque	✓	✓	✓	✓
Actuating times	✓	✓	✓	✓
ATF temperature	✓	✓	✓	

note1: Analog output is  $\pm 10V/F.S.$   
note2: Digital data is output by text data.

### Durability test

Mean rotational velocity, control mode, AGC/AMC mode, frequency, amplitude, and actuating times is set up.

One condition for one stage.

Peak value and waveform data is acquired.

#### Peak value

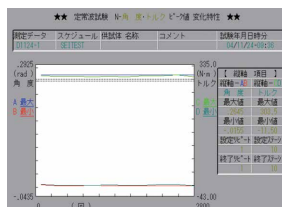

#### Waveform data

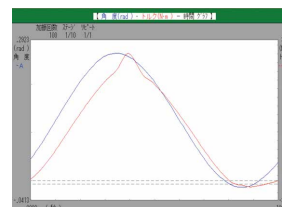

#### Lissajous data

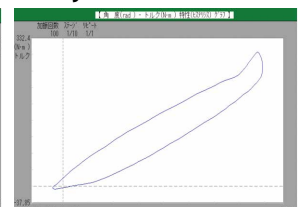

### Static spring test

Mean rotating velocity, control mode, reverse mode, moving velocity and return point is set up.

Static spring value (Go, Return and Both ways), hysteresis and creep condition in selected area is analyzed.

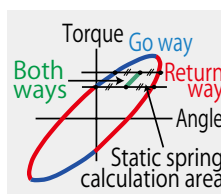

Static spring value

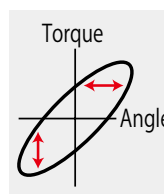

Hysteresis

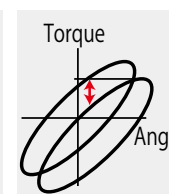

Creep value

#### Lissajous data (Angle-Torque)

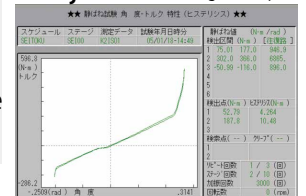

# Spin Torsional Test System

## System configuration



## System diagram

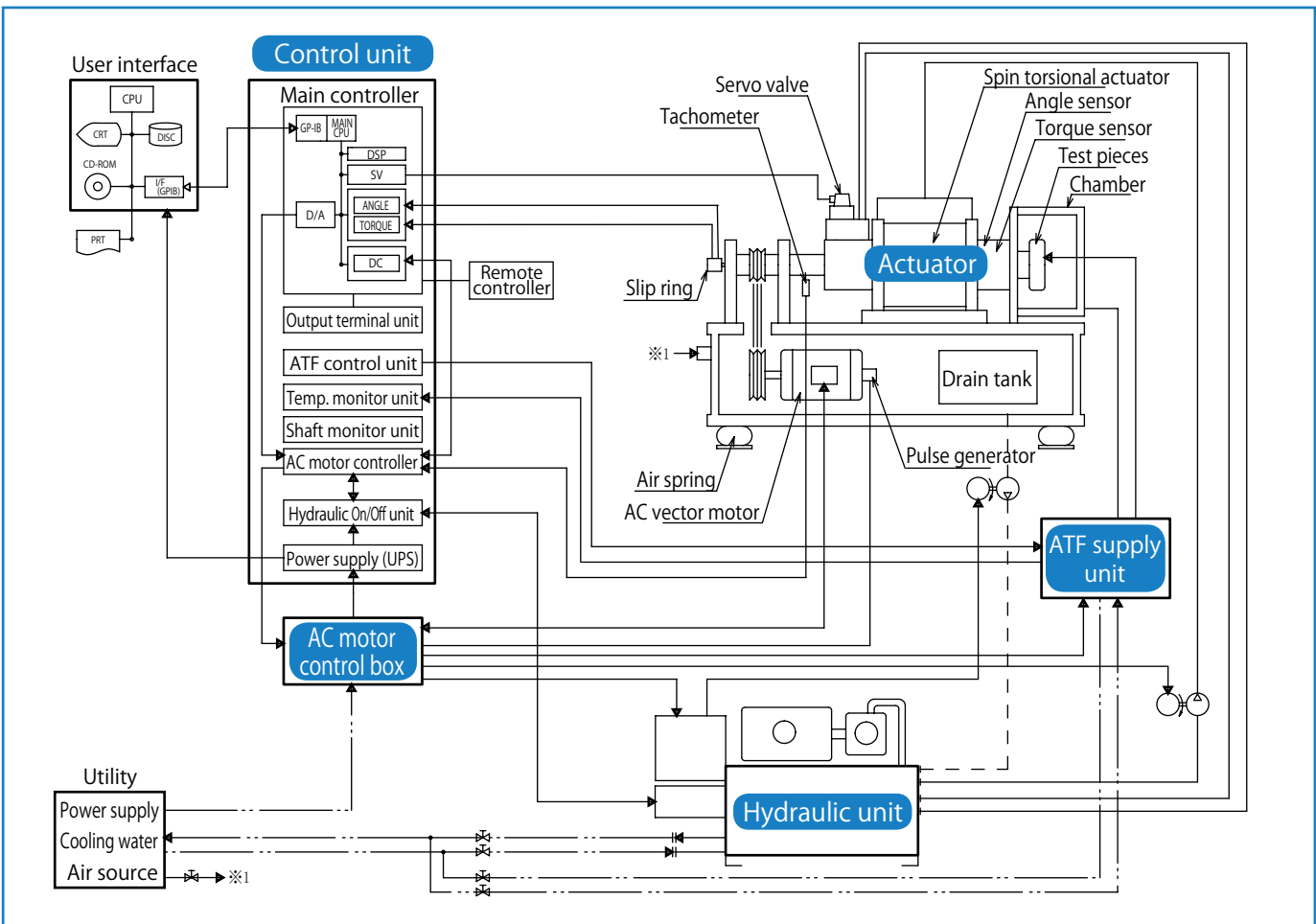



# Spin Torsional Test System

## Standard specifications (Model BPH-320-11)

### Actuator

Oscillation specifications	
Maximum torque	$\pm 1\text{kN}\cdot\text{m}$
Maximum angle	$\pm 50^\circ$
Maximum angle speed	$\pm 1000^\circ/\text{s}$
Maximum angle acceleration	$\pm 150000^\circ/\text{s}^2$
Frequency range	0.01 ~ 50Hz
Rotation specifications	
Rotational velocity range	$\pm 200 \sim 8000\text{rpm}$
Maximum rotation acceleration / deceleration	$\pm 100\text{rpm}/\text{s}$
Electric motor capacity	30kW

### Controller

Model	M2820
Control method	Full digital control
Control mode	angle, torque, velocity
Waveform	sine, triangular, square, sweep, ramp
AGC / AMC function	amplitude/mean, max/mini, standard wave/mean
External signal input	Input for controller 4 ports ( $\pm 10\text{V}$ ) Trigger input 4 ports (0 ~ +5V)
Monitor output	$\pm 10\text{V}/\text{F.S.}$ 4 ports (BNC connector)
Limiter function	Over limiter 4 points limiter
Power supply	AC100V 50/60Hz 0.5kVA (AC200V is available)
Installation	Rack-mounted

### ATF supply unit

Delivery pressure	max 0.5MPa
Flow rate	max 9.5L/min
Set temp. range	60 ~ 120°C

### Hydraulic unit

Motor capacity	37kW
Rated pressure	20.5MPa
Rated flow	106L/min (50Hz) 104L/min (60Hz)

### Utility (total facilities)

Power supply	AC200V 50/60Hz 3-phase 130kVA
Cooling water	125L/min 30°C or less Differential pressure 0.2MPa or more
Air source	2200NL/min 0.4MPa or more

### Performance curve

note: Conditions at no load.

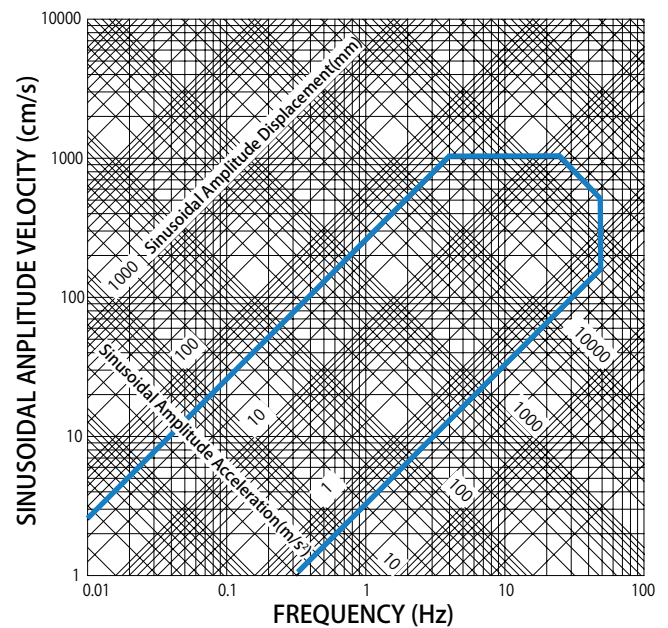

### Software

Schedule operation	
Pattern	<ul style="list-style-type: none"> <li>• Stages/up to 30 stages</li> <li>• Repeated times/up to 1,000 times</li> </ul> <p>note: Repeatedly conducted optionally combining stages of durability test and characteristic measurement.</p>
Durability test stage	<p><b>Rotation setting</b></p> <ul style="list-style-type: none"> <li>• Rotational velocity</li> <li>• Rotational velocity arrival time</li> </ul> <p><b>Actuating setting</b></p> <ul style="list-style-type: none"> <li>• Waveforms (sine, triangular, square)</li> <li>• Frequency (0.01 ~ 50Hz)</li> <li>• Control mode (angle, torque)</li> <li>• Amplitude (amplitude/mean, max/mini)</li> </ul> <p><b>Data acquisition setting</b></p> <ul style="list-style-type: none"> <li>• Wave, peak</li> </ul> <p><b>Limiter setting</b></p> <ul style="list-style-type: none"> <li>• Over limiter, 4 points limiter</li> </ul>
Static spring test stage	<p><b>Rotational setting</b></p> <ul style="list-style-type: none"> <li>• Rotational velocity</li> <li>• Rotational velocity arrival time</li> </ul> <p><b>Actuator setting</b></p> <ul style="list-style-type: none"> <li>• Control mode (angle, torque)</li> <li>• Reverse mode (angle, torque)</li> <li>• Moving velocity</li> <li>• Retention time</li> <li>• Preliminary actuating condition</li> </ul> <p><b>Data acquisition setting</b></p> <ul style="list-style-type: none"> <li>• Acquired points, sampling time</li> </ul> <p><b>Limiter setting</b></p> <ul style="list-style-type: none"> <li>• Over limiter</li> </ul>
Data analysis	
Durability	<ul style="list-style-type: none"> <li>• Peak (value/graph)</li> <li>• Wave (value/graph)</li> </ul>
Static spring	<ul style="list-style-type: none"> <li>• Static spring value, hysteresis, creep</li> <li>• History graph (static spring, hysteresis, creep)</li> </ul>

# Spin Torsional Test System

## Dimensions (Standard BPH-320-11)

note: The actual product size may differ depending on its specifications.

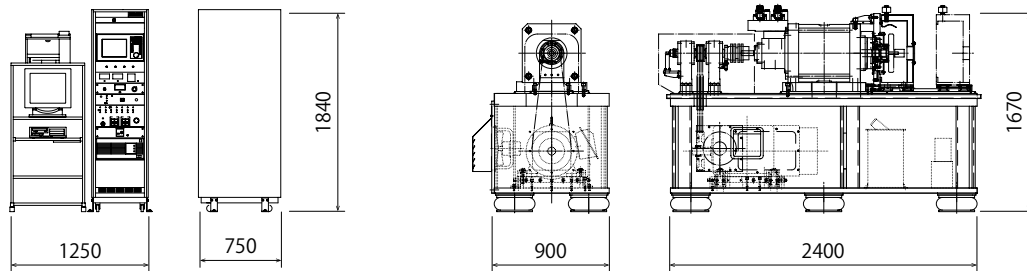

Control unit

Actuator

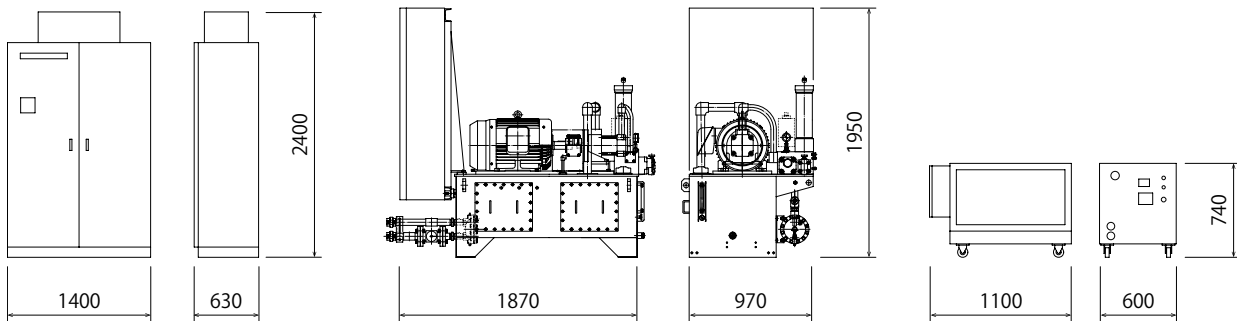

AC motor control box

Hydraulic unit

ATF supply unit

## Test piece installed size

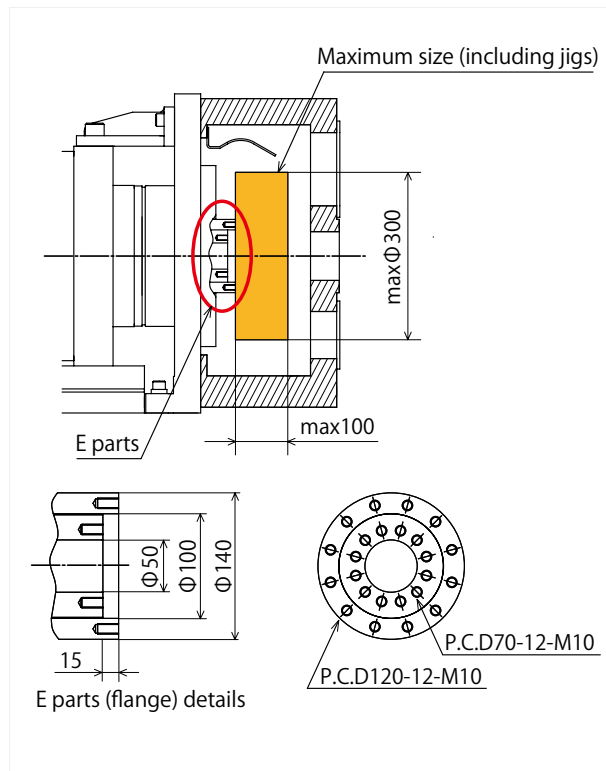

## Layout sample

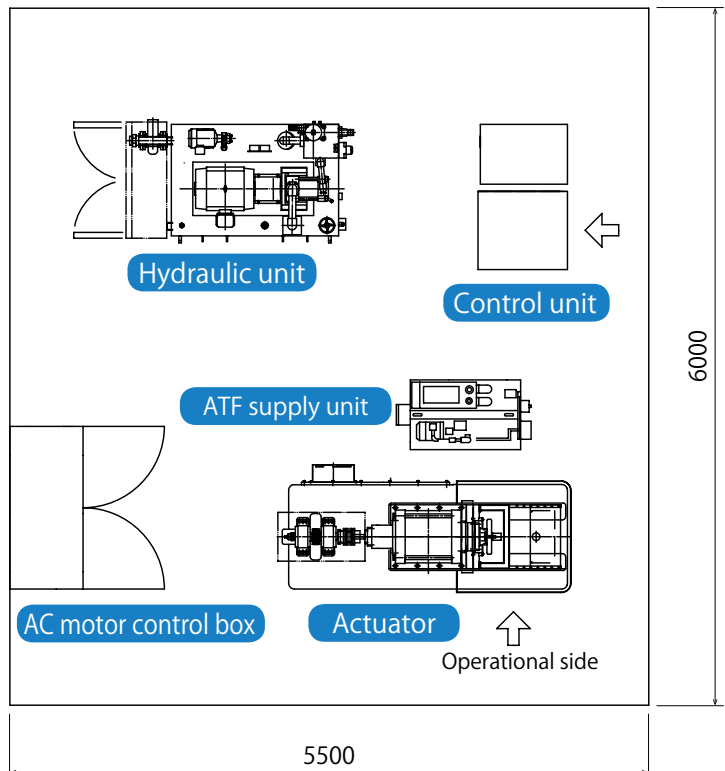

# Spin Torsional Test System

## Various types of products and options



**BPH-321-B2**  
 • For cars (MT)  
 • 5000rpm  
 •  $\pm 1.2\text{kN}\cdot\text{m} \pm 120^\circ$   
 • With chamber



**BPH-321-C2**  
 • For cars (AT)  
 • 8000rpm  
 •  $\pm 1.5\text{kN}\cdot\text{m} \pm 120^\circ$   
 • With ATF supply unit



**BPH-321-21**  
 • For cars (AT)  
 • 6000rpm  
 •  $\pm 2.0\text{kN}\cdot\text{m} \pm 50^\circ$   
 • With ATF supply unit



**BPH321-22**  
 • For cars (MT)  
 • 5500rpm  
 •  $\pm 2.0\text{kN}\cdot\text{m} \pm 120^\circ$   
 • With chamber



**BPH-321-31**  
 • For trucks (MT)  
 • 4000rpm  
 •  $\pm 3.5\text{kN}\cdot\text{m} \pm 50^\circ$   
 • With chamber



**BPH-321-32**  
 • For trucks (MT/AT)  
 • 4000rpm  
 •  $\pm 3.5\text{kN}\cdot\text{m} \pm 120^\circ$   
 • With chamber & ATF unit



**ATF Chamber**  
 For AT damper

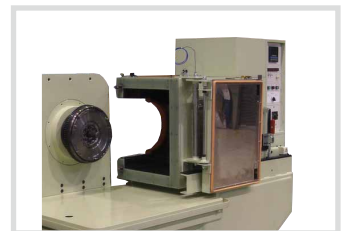

**Thermostatic chamber**  
 For MT damper



**Heating chamber**  
 For MT damper



**Flash photography chamber**  
 (Front door can be opened)

## Related products

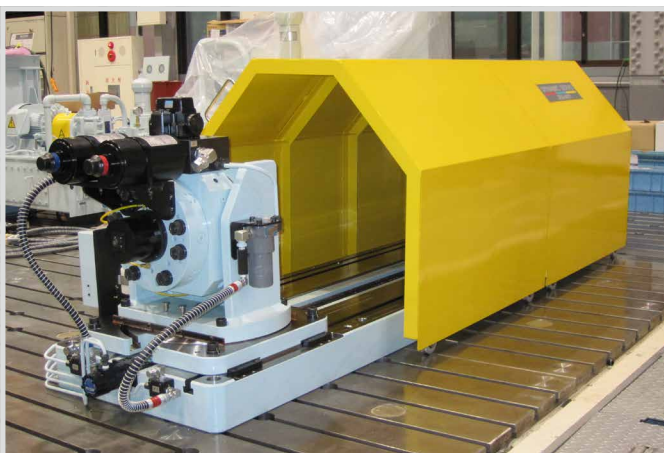

### Torsional test system

To test basic durability/static spring characteristic on clutch damper (no rotation)

- $\pm 10\text{kN}\cdot\text{m}$  50°~50Hz 1000°/s (no rotation)



### Driving absorption type of spin torsional test system

To evaluate wearing durability/abnormal noise on transmission. Combining drive motor, spin torsional actuator and absorption motor, transmission rotating + dynamic oscillation load is tested.

- Drive motor 3000rpm/4000rpm 196N·m/148N·m
- Torsional actuator ~200Hz max1300°/s
- Absorption motor 1000rpm/4500rpm 570N·m/130N·m

**DYNAMIC SERVO**  
SAGINOMIYA

**SAGINOMIYA**  
SEISAKUSHO,INC.

<http://www.saginomiya-global.com/en/>

Testing Equipment Tel : +81 3 6205 9126 Fax : +81 3 6205 9127  
Sales Department Shinjuku Garden Tower 22F  
8-2, Okubo 3-chome, Shinjuku-ku, Tokyo, 169-0072 Japan  
**E-mail [dynamic-servo@saginomiya.co.jp](mailto:dynamic-servo@saginomiya.co.jp)**

Osaka Sales Office Tel : +81 6 6385 8011 Fax : +81 6 6384 0859  
10-28, Hiroshibacho, Suita-shi, Osaka, 564-0052 Japan

Nagoya Sales Office Tel : +81 52 224 7120 Fax : +81 52 224 7121  
1-13, Simizu 4-chome, Kita-ku, Nagoya-shi, Aichi, 462-0844 Japan



**NOTES FOR SAFETY**

Failure to read and follow all instruction carefully before installing or operating the product could cause personal injury and / or property damage.

Specifications are subject to change without notice.